

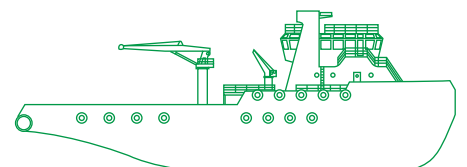

Captain Rolando

Ocean towing/towing/utility tug

Lorem ipsum dolor sit amet, consectetur adipiscing elit, sed diam nonummy nibh euismod tincidunt ut laoreet dolore magna aliquam erat volutpat. Ut wisi enim ad minim veniam, quis nostrud exerci tation ullamcorper suscipit lobortis nisl ut aliquip ex ea commodo consequat. Duis autem vel eum iriure dolor in hendrerit in vulputate.



Dimensions

Length Overall | 48 metres
LBP | 45.5 metres
Breadth Moulded | 13 metres
Depth Moulded | 5.8 metres
Maximum Draft | 4.8 metres

Tonnage

GRT | 874 tons
NRT | 262 tons
Deadweight | 893 tons

Deck equipment

Towing/Anchor Handling | Electro-Hydraulic Waterfall Double Drum
Winch | Brake Holding Capacity @100 tons
Towing Wires | 2x 1000 metres 42 mm diameter FSWR wires
Anchor Handling Wire | 300 metres x 48 mm diameter FSWR work wire
Tugger Winch | 2x Electro Hydraulic Winches x 5 tons each
Capstan | 2x Electro Hydraulic Winches x 3 tons each
Stern Roller | SWL 60 tons 3.5 metres x 1.5 metres
Anchor Windlass | Electro-hydraulic 5 tons
Deck Crane | 2 t @9 metres, Hydraulic Operated Telescopic
Cargo Fuel Pump | 30 m³/hr at 50 metres head, 50 m³/hr at 30 metres head
Reefer Points | 4x AC 414V,3 Phase,50Hz, 32Amp, 4 x AC 220 V,3 Phase,50Hz, 32Amp

Performance

Speed | 13 knots
Bollard Pull | 45.1 metric tons
Clear Deck Area | 22 metres x 12 metres = 264 m²

Machinery/propulsion

Main Engine | 2x 1350 bhp @1000 rpm Wartsila 6L20
Propeller | 2x CPP in Nozzles x 3 metres diameter
Generator | 1x Diesel Main Generator 250 kW 415v 3Ph 50hz, 2x Shaft Alternators each 350 kW 415v 3Ph 50hz, 1x Emergency Generators 85 kW 415v 3Ph 50hz
Bow Thruster | 1x 250 kW @3.8 tons (38kn) thrust

Registration

Year of Build | 2000
Builder | President Marine Pte Ltd
Port of Registry | Kingstown
Flag | St Vincent and the Grenadines
Call Sign | J8B5247
Official Number/IMO Number | 11720/9206358
Class | Bureau Veritas/BV Registry No.00778X
Class Notation | I + HULL + MACH Tug Deep Sea
Owner | Mubarak Marine LLC

Capacity

Fuel Oil | 654 m³
Fresh Water | 262 m³
Foam | 8.4 m³
Oil Dispersant | 6.4 m³
Oil Spill Recovery Tank | 95 m³

Accommodation

1 man cabin | 2x = 2
2 men cabin | 7x = 14
4 men cabin | 4x =16
Total | 32 Berths

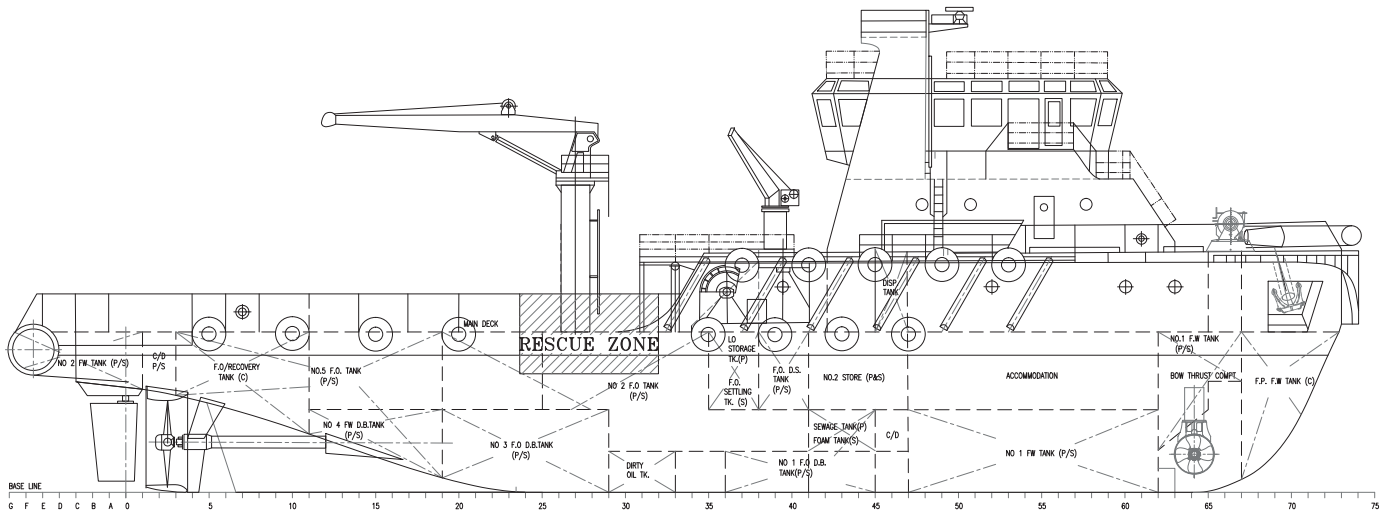

Outboard profile

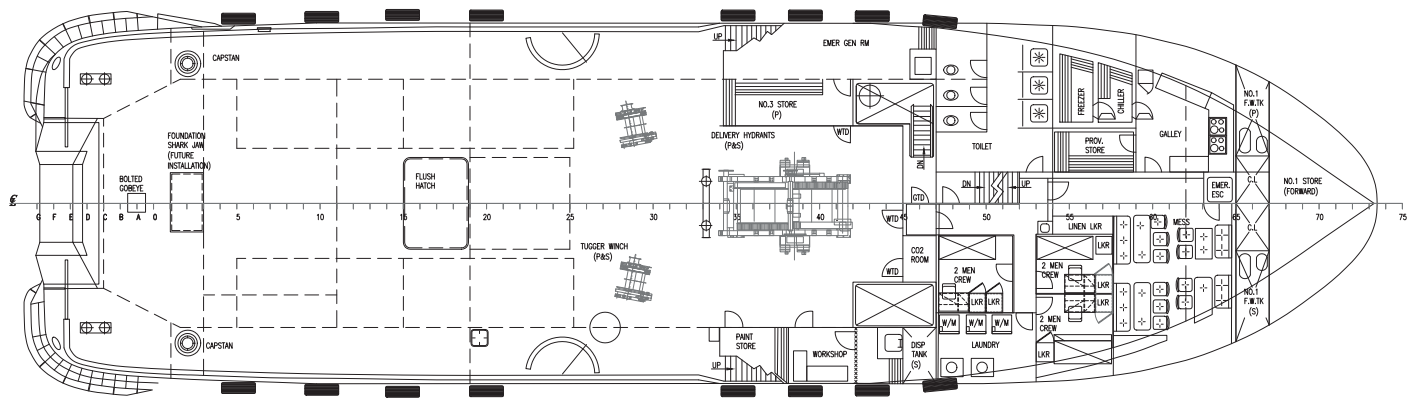

Main deck

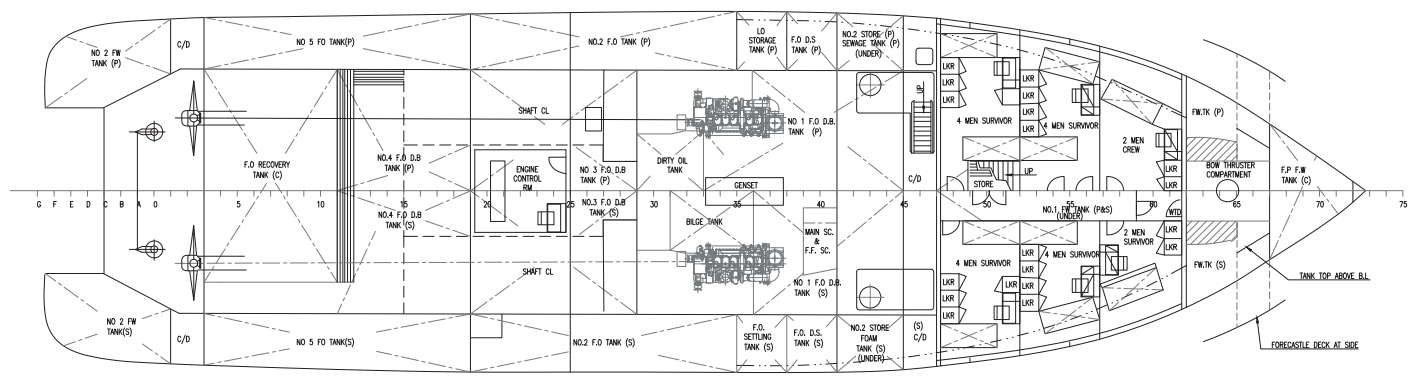

Below main deck

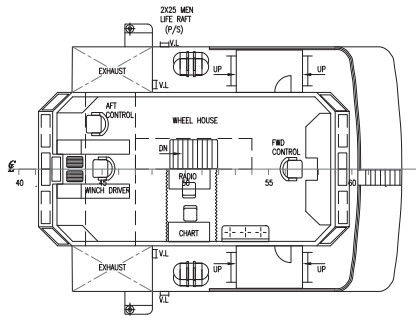

Bridge deck

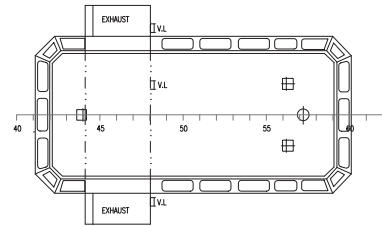

Wheelhouse top

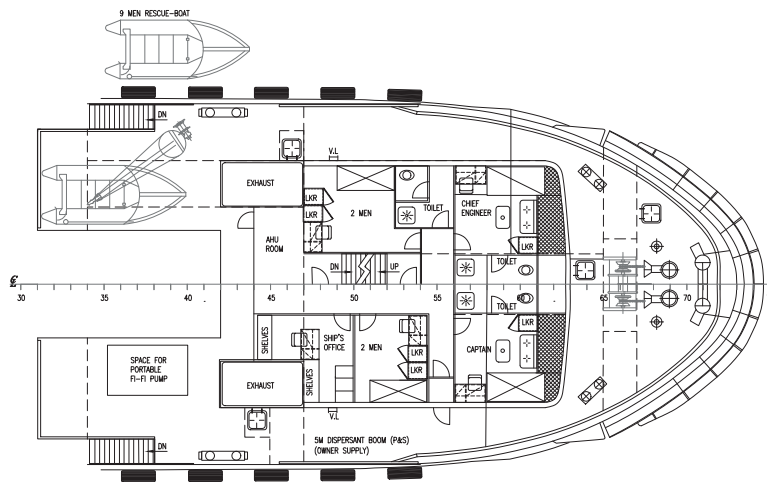

Forecastle deck

Mubarak Marine LLC | PO Box 7220 | Dubai Maritime City | UAE
 T+971 4 586 5200 | F +971 4 586 5299 | marketing@mubarak.ae | mubarakmarine.com

Revision January 2022 | All technical details are provided as a guide only and are subject to owner's changes without notice